

S18 Series Sensors (DC Voltage)



Installation Guide

For complete technical information about this product, including dimensions, accessories, and specifications, see <http://www.bannerengineering.com> and search for datasheet 121522.



WARNING: Not To Be Used for Personnel Protection

Never use this device as a sensing device for personnel protection. Doing so could lead to serious injury or death. This device does not include the self-checking redundant circuitry necessary to allow its use in personnel safety applications. A sensor failure or malfunction can cause either an energized or de-energized sensor output condition.

Models

Sensing Mode	Range	LED	Output	Model ¹
<p>OPPOSED</p>	20 m (66 ft)	Infrared 950 nm	-	S186E
			NPN	S18SN6R
			PNP	S18SP6R
<p>RETRO</p>	2 m (79 in)	Infrared 950 nm	NPN	S18SN6L
			PNP	S18SP6L
<p>POLAR RETRO ²</p>	2 m (79 in)	Visible Red 680 nm	NPN	S18SN6LP
			PNP	S18SP6LP
<p>DIFFUSE</p>	100 mm (4 in)	Infrared 880 nm	NPN	S18SN6D
	300 mm (12 in)		PNP	S18SP6D
			NPN	S18SN6DL
	PNP		S18SP6DL	
<p>FIXED-FIELD</p>	25 mm (1 in) cutoff	Infrared 880 nm	NPN	S18SN6FF25
	50 mm (2 in) cutoff		PNP	S18SP6FF25
			NPN	S18SN6FF50
	100 mm (4 in) cutoff		PNP	S18SP6FF50
			NPN	S18SN6FF100
	PNP		S18SP6FF100	

¹ Standard 2 m (6.5 ft) cable models are listed.

- To order the 9 m (30 ft) cable models, add suffix W/30 (for example, S186E W/30).
- To order the 4-pin M12/Euro-style QD models, add suffix Q (for example, S186EQ). A model with a QD connector requires a mating cable.

² Use polarized models when shiny objects will be sensed.



Wiring Diagrams

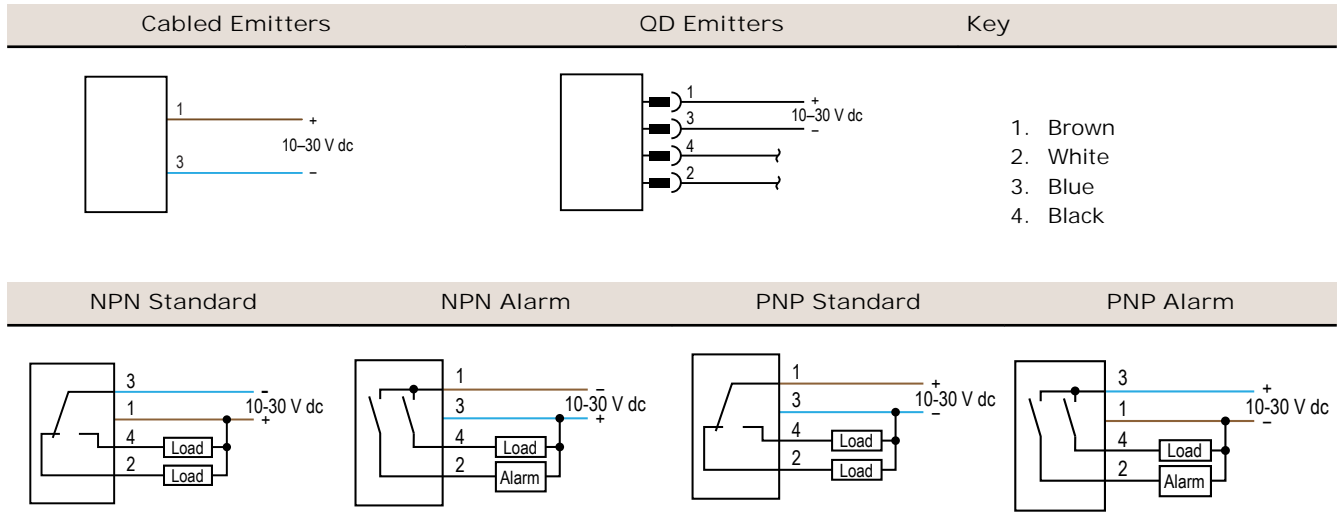

Wiring for the quick disconnect (QD) models is functionally identical.

Dimensions

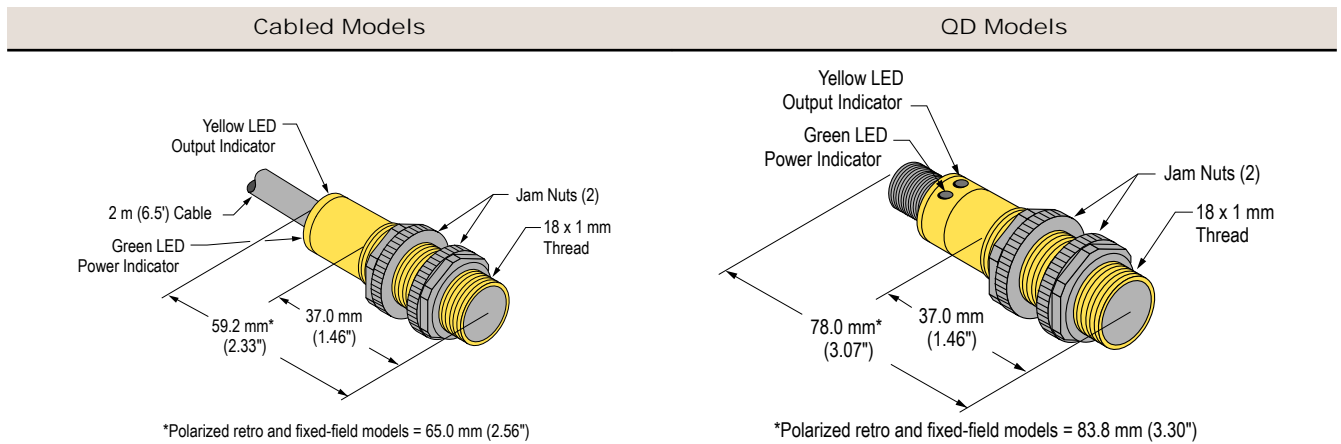

Specifications

Supply Voltage and Current

10 to 30 V dc (10% maximum ripple)
Supply current (exclusive of load current):

- Emitters, non-polarized retroreflective, retroreflective, diffuse models: 25 mA
- Receivers: 20 mA
- Polarized retroreflective models: 30 mA
- Fixed-field models: 35 mA

Supply Protection Circuitry

Protected against reverse polarity and transient voltages

Indicators

Two LEDs (green and amber):

- Green on: power to sensor is on
- Green flashing: output is overloaded
- Amber on: N.O. output is conducting
- Amber flashing: excess gain marginal (1 to 1.5x) in light condition

Construction

Housing: PBT polyester housing
Lens: polycarbonate (opposed-mode) or acrylic (other models)

Connections

2 m (6.5 ft) integral cable; 9 m (30 ft) integral cable; or 4-pin M12/
Euro-style quick-disconnect fitting

Operating Conditions

-40 °C to +70 °C (-40 °F to +158 °F)
90% at +50 °C maximum relative humidity (non-condensing)

Environmental Rating

Leakproof design rated NEMA 6P, DIN 40050 (IP69K)

Vibration and Mechanical Shock

All models meet Mil. Std. 202F requirements. Method 201A (Vibration; frequency 10 to 60 Hz, max., double amplitude 0.06 in acceleration 10G).
Method 213B conditions H&I.
Shock: 75G with unit operating; 100G for non-operation

Certifications



All models, except S186E are UL approved.

Output Configuration

SPDT solid-state dc switch; Choose NPN (current sinking) or PNP (current sourcing) models
Light Operate: N.O. output conducts when sensor sees its own (or the emitter's) modulated light
Dark Operate: N.C. output conducts when the sensor sees dark; the N.C. (normally closed) output may be wired as a normally open marginal signal alarm output, depending upon wiring to power supply (U.S. patent 5087838)

Output Rating

150 mA maximum (each) in standard wiring. When wired for alarm output, the total load may not exceed 150 mA.
OFF-state leakage current: < 1 microamp at 30 V dc
ON-state saturation voltage: < 1 V at 10 mA dc; < 1.5 V at 150 mA dc

Output Protection Circuitry

Protected against false pulse on power-up and continuous overload or short circuit of outputs

Output Response Time

Opposed mode models: 3 ms ON, 1.5 ms OFF
Retroreflective, fixed-field, and diffuse mode models: 3 ms ON and OFF
NOTE: 100 ms delay on power-up; outputs do not conduct during this time.

Repeatability

Opposed mode models: 375 µs
Retroreflective, fixed-field, and diffuse mode models: 750 µs
Repeatability and response are independent of signal strength.

Required Overcurrent Protection



WARNING: Electrical connections must be made by qualified personnel in accordance with local and national electrical codes and regulations.

Overcurrent protection is required to be provided by end product application per the supplied table.
Overcurrent protection may be provided with external fusing or via Current Limiting, Class 2 Power Supply.
Supply wiring leads < 24 AWG shall not be spliced.
For additional product support, go to <http://www.bannerengineering.com>.

Supply Wiring	Required Overcurrent Protection
20	5.0 Amps
22	3.0 Amps
24	2.0 Amps
26	1.0 Amps
28	0.8 Amps
30	0.5 Amps

Accessories

4-Pin Threaded M12/Euro-Style Cordsets				
Model	Length	Style	Dimensions	Pinout (Female)
MQDC-406	1.83 m (6 ft)	Straight		<p>1 = Brown 2 = White 3 = Blue 4 = Black</p>
MQDC-415	4.57 m (15 ft)			
MQDC-430	9.14 m (30 ft)			
MQDC-450	15.2 m (50 ft)			

4-Pin Threaded M12/Euro-Style Cordsets				
Model	Length	Style	Dimensions	Pinout (Female)
MQDC-406RA	1.83 m (6 ft)	Right-Angle		
MQDC-415RA	4.57 m (15 ft)			
MQDC-430RA	9.14 m (30 ft)			
MQDC-450RA	15.2 m (50 ft)			

- 1 = Brown
- 2 = White
- 3 = Blue
- 4 = Black

Banner Engineering Corp. Limited Warranty

Banner Engineering Corp. warrants its products to be free from defects in material and workmanship for one year following the date of shipment. Banner Engineering Corp. will repair or replace, free of charge, any product of its manufacture which, at the time it is returned to the factory, is found to have been defective during the warranty period. This warranty does not cover damage or liability for misuse, abuse, or the improper application or installation of the Banner product.

THIS LIMITED WARRANTY IS EXCLUSIVE AND IN LIEU OF ALL OTHER WARRANTIES WHETHER EXPRESS OR IMPLIED (INCLUDING, WITHOUT LIMITATION, ANY WARRANTY OF MERCHANTABILITY OR FITNESS FOR A PARTICULAR PURPOSE), AND WHETHER ARISING UNDER COURSE OF PERFORMANCE, COURSE OF DEALING OR TRADE USAGE.

This Warranty is exclusive and limited to repair or, at the discretion of Banner Engineering Corp., replacement. IN NO EVENT SHALL BANNER ENGINEERING CORP. BE LIABLE TO BUYER OR ANY OTHER PERSON OR ENTITY FOR ANY EXTRA COSTS, EXPENSES, LOSSES, LOSS OF PROFITS, OR ANY INCIDENTAL, CONSEQUENTIAL OR SPECIAL DAMAGES RESULTING FROM ANY PRODUCT DEFECT OR FROM THE USE OR INABILITY TO USE THE PRODUCT, WHETHER ARISING IN CONTRACT OR WARRANTY, STATUTE, TORT, STRICT LIABILITY, NEGLIGENCE, OR OTHERWISE.

Banner Engineering Corp. reserves the right to change, modify or improve the design of the product without assuming any obligations or liabilities relating to any product previously manufactured by Banner Engineering Corp.